



PT ROTOTEG **TOTAL SOLUSI**

Your Trusted Solution



PRODUCT CATALOGUE

Material Handling Solution

CONVEYOR BELT

As a leading conveyor belt supplier in Indonesia, we prioritize quality and safety ensuring our products meet the highest standards. We are one of the most reliable conveyor belt supplier in Indonesia, providing excellent quality in term of products and services.

Our range of product:

- **Textile Belt**
The multi purpose textile belt for general to highly demanding applications.
- **Steel Belts**
Outstanding impact and cutting resistance: a unique and unrivalled steel carcass construction.

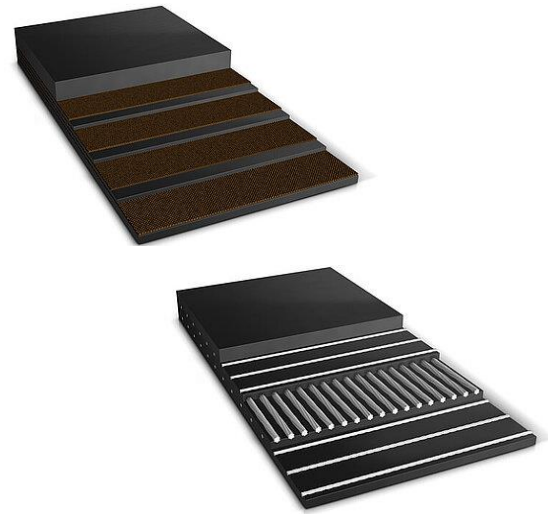

BELT CLEANER

Belt cleaners are required for both the carrying side and the non carrying side of the belt. Material falling on the non-carrying side of the belt needs to be arrested before it get trapped in the tail pulley to cause damage to the lagging and sway of the belt. The carrying side needs cleaning when carried material is sticky in nature. To deflect the material coming on the non-carrying side deflector belt plows are used. Such plows can be selected from number of available sources or can be locally made considering that the rubber used in it should be softer than the surface of the belt conveyor. It must be easy to install and maintain. Our range of products:

- **Primary Belt Cleaner**
- **Secondary Belt Cleaner**

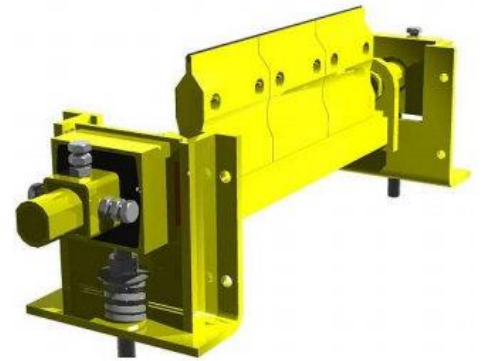

PULLEY DESIGN & MANUFACTURE

We designed and manufactured to the highest engineering standards to ensure long, reliable, fatigue-resistant service life. Locally manufactured, Our pulleys are constructed from either pipe or rolled steel pipe.

ROLLER SUPPLIES

Our roller are manufactured using steel roller design, equipped with rubber discs assembled, side by side. The roller will reduce shock and vibration in carrying out its function in transporting materials. They resist and absorb pressures against the conveyor belt. Our range of products:

- **Impact Roller**
- **Steel Roller**

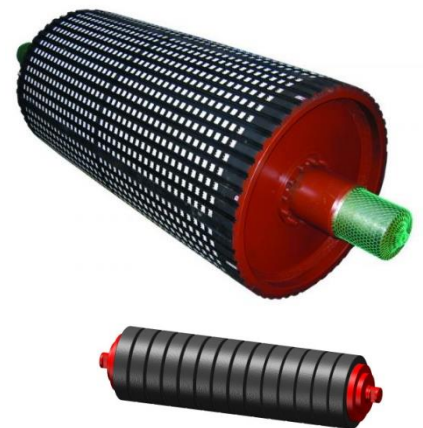

SAFETY DEVICE

Detect at an early stage abnormally of belt speed or swaying and tearing of belt for constant supply of material and stable operation of belt conveyor.



PULL CORD SWITCH

Emergency stop switch when any accident occurs at belt conveyor.



BELT SWAY SWITCH

Protective switch which detects the conveyor belt misalignment and outputs alarm signal and emergency stop signal.



BELT ALIGNMENT SWITCH

Protective switch which detects the conveyor belt misalignment.



CHUTE SWITCH

Emergency switch which stops conveyor when chute is clogged.



SPEED SWITCH

For detecting the revolving speed of mechanical shaft.



LIMIT SWITCH

Emergency stop switch when any accident occurs at belt conveyor.



WARNING HORN

It is aimed to prevent dangerous situations.



FLOW SWITCH

Detect flow or no flow material .



PADDLE SWITCH

Detect by the paddle revolving at low speed being buried and got stuck in the materials.



CAPACITY LEVEL SWITCH

Measure object as medium and also uses the sensing rod to detect capacitance between the sensing rod and the vessel wall.



DIAPHRAGM LEVEL SWITCH

Diaphragm level switch is sensor with an electrical contact output. When material in the bin exceeds the level of the diaphragm level switch, a sensitive micro-switch is activated.



INDICATING LIGHT

Give the light indicator to prevent dangerous situations.

Material Handling Solution

GEARMOTOR, ELECTRIC MOTOR, & MOTION CONTROL

We specialize in meeting your needs with our high capacity, high dynamic, precise, of **gearmotors**, **planetary gearboxes** and **electric motors** for many applications and industrial sectors.

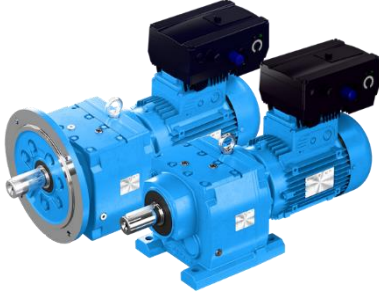

GEARMOTOR



ELECTRIC MOTOR



MOTION CONTROL

When compared to those on the market today, We have one of the broadest ranges of gear reducers and gearmotors; torques available from 30 Nm to 3 million Nm. It will therefore always be possible to find the product most suited to the customer's needs.

Satisfy all the customers' requests, assuring a high-quality standard: this is the permanent objective of our skilled department for the manufacture of electric motors.

Discover the new decentralized inverters, designed to be installed directly on Rossi high efficiency electric motors in combination with a wide range of gearboxes. Thanks to a compact design and to the high degree of protection level, this solution is suitable for each environmental condition.



INDUSTRIAL GEAR UNIT

A wide range of gearmotors and gear reducers, combined with a high level of engineering expertise, decades of experience. Highest production quality and global services make our product a valuable partner if you need premium industrial gear.



GEAR REDUCER

Whether you need precision or power, we offer solutions for nearly every application and industry. It will always be possible to find the product most suited to your needs.

ELECTRIC MOTOR



We offer electric motors to support various applications with reliable, high efficiency and low maintenance products that are ready to provide solutions and full support for your needs. Our product supply get recognition in the marine, oil & gas, power generation, co-generation, hydro, and other industrial sectors.

DRIVES

We has extensive experience in providing variable speed drives and HVAC drives for a verity of solutions and services, including leisure, Hotel and resorts, hospitals, commercial buildings, retail and distribution, lifts and cranes, industrial processes, automation, OEMs, and Sub-distribution. Our AC drives are dedicated, reliable and user-friendly product that fit your specific application and reduce your total cost of ownership. Our AC Drives are independent of motor manufacturers. We offer a complete range of AC Drives designed to save energy, maximize efficiency and reduce



VLT HVAC DRIVE

Bring enhanced intelligent fan and pump control.



VLT AUTOMATION DRIVE

Tougher and more intelligent than it has ever been before.



VLT MICRO DRIVE – THREE PHASE

Is small, powerful and durable. Its compact size and minimal commissioning requirements can save on panel space and the cost of installation



NXP

NXP Air Cooled drives offer precision and power to application that require a robust and dynamic performance



GENERAL PURPOSE

One drive, extensive applications. The drivee is a workhorse for a wide range of industrial application.



THREE PHASE

Fast installation and set-up are possible due to easy-access terminals, integral DIN rail mounting and the parameter copying tool which can done setting without needing mains power.

Material Handling Solution

TOTALLY INTEGRATED AUTOMATION

Totally Integrated Automation offers automation development, flexible machine concepts, transparent operation, and sustainable solutions that enable access to calculate data and optimize the product carbon footprint. Our product supply constantly improving and expanding to be future proof and adaptive to existing and upcoming challenges.



LOGO!

- The compact, easy-to-use and low-cost solution for simple control tasks
- Compact, easy to operate, universally applicable without accessories
- "All in one": Integrated display and operator panel.



S7-1200

The intelligent choice for compact automation solutions with integrated I/Os, communication functions and technology functions for automation tasks in the lower to middle performance range. They are available in standard and fail-safe versions.



S7-1500

- A modular, scalable, and universally usable system in IP20 degree of protection
- The system solution for a variety of automation applications in discrete automation



S7-300

- The modular mini PLC system for the low and mid-performance ranges
- With comprehensive range of modules for optimum adaptation to the automation task
- High performance thanks to a range of integrated functions



S7-400

- Can be flexibly adapted to your requirements. The redundant configuration further increases system availability
- Long term availability
- Can be integrated into a single automation system.

MAGNETIC SEPARATOR



RCYB SERIES

- Strong magnetic field intensity.
- Simple installation, convenient to operate, high efficiency and stable performance, free maintenance.
- Core guaranteed 10 years under normal circumstances; Nevertheless than 5% demagnetization.



RCYD(C) SERIES

- Made of rare earth NdFeb
- Energy saving easy to install and convenient to use.
- High efficiency and stable performance, good operational, reliability and flexibility.



RCDB SERIES

- Sustain and reliable magnetic field, with strong magnetic force.
- Compact structure, light weight, and easy to maintain.
- Featuring with dust and rain-protection. It can run in the harsh condition.

METAL DETECTOR

Series GJT iron ore metal detector is the latest product in metal detecting field. In circuit design, this product adopts digital phase shifting and related detecting technologies, which are the latest metal detecting technologies. With stable performance, high detecting sensibility and strong disturbance resisting ability, series GJT metal detector is widely used for belt conveyors in thermal power, cement, paper, mining, forestry, environment protection, building materials and other industries.

Feature:

1. Its sensors shell is made of stainless steel or plastics steel, good anti corrosion ability, suitable for terrible environment and easy to install.
2. Control cabinet adopts dual-door structure with stainless steel shell, waterproof and dustproof.
3. Position and belt speed can be adjusted and the types of mineral can be selected, digit set, good stability and wide application.
4. Sensitivity can be adjusted intelligently. (The metal detector upon detecting the presence of metal, the conveyor belt becomes automatically stops.)
5. Multi-level anti-inference measures are taken to avoid wrong actions effectively.



Material Handling Solution

DUST COLLECTOR

Dust Collector is a dust or smoke suction machine for industrial processes. In industrial processes such as pouring material, welding, sifting flour, the process of falling material from conveyor to another conveyor, and several other important applications that cause dust and smoke to be inhaled by a dust collector machine. The dirty air then filtered and separated between dust and air, dust enters the shelter while the air is discharged outside the factory so that air pollution can be overcome.



PULSE JET BAG FILTER



SHAKE BAG FILTER



CENTRIFUGAL FAN



WET SCRUBBER

COAL SAMPLER

Automatic sampler on Conveyor belt with PLC control.

Specification:

1. Material Handling : coal
2. Lump size max: 50mm
3. For conveyor speed 3,5 m/s
4. Capacity 1000 TPH
5. Belt Width 1200mm
6. Automatic operation program set on time/ as well as manual local operation via push button activation
7. Remote control with SIEMENS PLC, touch screen and control software.



WEIGHBRIDGE

Proudly servicing Indonesian transport, logistics, quarries, mining, waste management, and agricultural, our pedigree as Indonesia's most experienced weighbridge manufacturer. **ROTOTEG** have positioned us as major weighbridge supplier and installer for across Indonesia.

Whether your operations are temporary or permanent, expanding or downsizing; we have a solution for you. We've proudly manufactured custom weightbridges to every conceivable industry across Indonesia. We handle each and every custom weighbridge request with a rich knowledge of our customer's needs and requirements.

Benefits:

1. By having complete control over your payload, your operations can benefit by precisely knowing the weight and axle load distribution, leading to optimizing your payloads profitability.
2. Our Weighbridge will enable you to have accurate visibility over your vehicle load, providing you with the tools to prevent overloading, preventing costly fines and improving road safety.
3. Ensure your supply chains are protected by the reassurance provided by a weighbridge.
4. Ensure your vehicle aren't overloaded and protect your process.
5. Increase your operational efficiencies and effectiveness by having grater control and optimization potential over your operations.
6. You can effectively monitor and charge your customer via load weight, with the peace of mind knowing you are getting highly accurate readings and not losing potential profits.



Transport & Logistics



Mines & Quarries



Waste Management



Agriculture

COAL DUST CONTROL

Our effective, low cost solution integrate customized levels of operational control while helping you meet governmental regulations, reduce housekeeping costs and increase operational efficiency.

Application:

- Pile Sealant
- Rail Car Topper
- Truck Top Sealant
- Slope Encrusting
- Haul Road
- Stackout suppression
- Transfer Point
- Rail Car Unloading
- Conveying System
- Anti Oxidizers

BENEFITS:

- Minimizes water addition
- Cost competitive mid-term residual agents
- Requires less equipment at fewer application points
- Enviromentally safe



SPONTANEOUS COMBUSTION INHIBITOR

- Minimize Spontaneous Combustion
- Allow for increase storage and transport times
- Minimizes risk associated with hot coal storage and handling
- Reduces dust during handling

When sitting for long periods of time, coals, such as those from Indonesia and the Powder River Basin have the tendency to self heat. This creates the possibility of hot spots and fires. **CHEMPO**, a blend of chemicals, stabilizes coal and reduces spontaneous heating during transport and storage, minimizing risk and safety concerns. The result is less risk and a safer operation with no effect on the coals performance.

CHEMPO coal spontaneous combustion and oxidation inhibitor is a unique blend of organic chemicals designed to slow the spontaneous heating of coal during transport and storage.



ROTOTEG is your contact for ready-to-operate, custom-designed pump skid units with a small-footprint design.

Our pump expertise and years of experience across various industries enable us to handle every stage in the creation of a pump skid – from design right through to commissioning. Our portfolio includes systems featuring a **DUST SUPPRESSION PUMP SKID**, **WET FOG PUMP SKID**, and **WATER SUPPLY PUMP SYSTEM**



Dust Suppression Pump Skid

- Easy to install and maintain
- Increase safety of loading material
- Works efficiency reduce dust pollution
- The system utilizes an existing water system and a single chemical pump provide a balanced flow of wet surfactant solution to the application points.
- Chemical rates are adjusted based on water hardness, amount of fines in coal and type of application.
- On-off operation for performance test, automated for permanent installation using on belt detection and belt running signal or metal detector at hopper.
- Bypass waterline system is available for operation back up whenever needed for solenoid valve maintenance.



Dust Fogging Pump Skid

- Easy to install and maintain
- Increase safety of loading material
- Works efficiency reduce dust pollution
- The system utilizes an existing water system
- On-off operation for performance test, automated for permanent installation using on belt detection and belt running signal or metal detector at hopper.

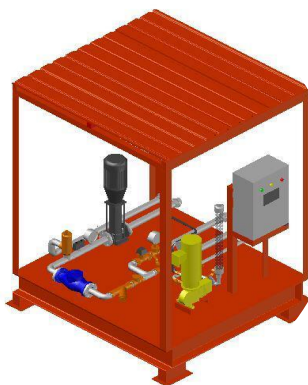

Water Supply Pump Skid

We don't leave anything to chance: We choose all the pumps, materials, and accessories for our pump skids. We guarantee the total function of the module, enabling us to provide a turnkey solution.

Our skids are designed according to specific requirements and the available space. And, of course, we take all national and international regulations into consideration. Our service covers everything from assembly, installation on frames, acceptance, and approval through to delivery, on-site installation, and commissioning.

HDPE Pipe

As the demand for efficient and sustainable solutions continues to grow, we take pride in our ability to offer a complete range of HDPE pipes, fittings, fusion services and custom fabrication, which have earned the preference of municipalities and mine across Indonesia. Our HDPE offerings are engineered to exhibit superior durability, resistance to corrosion, and cost-effectiveness in comparison to traditional piping materials. These attributes make HDPE the optimal choice for waterworks and mining operations where productivity, downtime reduction and safety are critical considerations. Our team is committed to providing customized solutions, which are tailored to enable you to attain your project objectives.

For customer satisfaction, we are committed to giving so much more than just supplying pipes. Our experts are ready to provide explanations and training to help problems faced by consumers before and during installation in the field. Our after-sales service can also always be relied on to receive complaints and help provide solutions to problems that arise after the pipes are installed.

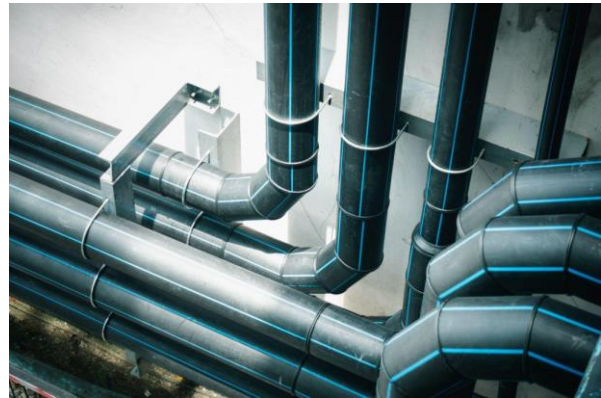

ROTOTEG has an extensive portfolio of leading safety solutions in Indonesia. Our product will help you build an enduring of safety that minimizes injuries and maintains a more protective and productive workplace. We can offer you a wide choice of safety equipment and supplies while assisting you with comparisons across all major brands.

Fire Extinguisher



**PORTABLE FIRE
EXTINGUISHER**



**WHEELED FIRE
EXTINGUISHER**



**AUTOMATIC FIRE
EXTINGUISHER**



**THERMATIC FIRE
EXTINGUISHER**

General Supply

Fire Fighting & Safety Equipments



HYDRANT BOX



FIRE EXTINGUISHER BOX



FIRE HOSE



HOSE REEL



HOSE COUPLING



HYDRANT PILLAR



HYDRANT CONNECTION



GUN NOZZLE



GROUND MONITOR



NOZZLE MONITOR



MOBILE FOAM TROLLEY



FIRE PUMP



SAFETY HELMET



SAFETY GOOGLES



PROTECTIVE APPAREL



SAFETY SHOE



MASK



NECKSHIELD



HOSE PACK

COATING SERVICES

ROTOTEG has the expertise to deliver quality results for your custom coating project. We are fully certified to repair existing coatings and execute new project, backed by our outstanding warranty.

Our range of services :

- **PROTECTIVE COATING**

We provide a range of specialist protective coating for your property to enhance its durability against the burdens of heavy machinery, chemical spills and other property exposure conditions.

- **FLOOR COATING**

We offer a variety of industrial floor coating services including: epoxy, MMA, and Urethane cements. Perfect for warehouse and factories that need a durability



BULK MATERIAL HANDLING ASSESSMENT

Bulk Material Handling Assessment is design for fixing any issues that threaten to halt production. The purpose of a succesful assessment is not to simply identify problems, but to identify the root cause of those problems. Simply telling an operator that the belt is dirty and suggesting a product to "fix" the problem is not a best practice when it comes to assessments. Our expert will tell you why it is happening and why the suggested solution will work for you long term.

Our Assessor will look at the conveyor system holistically and take into account many problems that could be impacting productivity such as carryback, spillage, slippage, belt wear and load point stress, and coal dust.



OPERATIONAL SERVICES

Our imperative is to help mining organisations perform at their best.

We do this through our powerful combination of mining industry expertise and technology to bring greater visibility and understanding of the impact of your current practices, across physical, financials and emissions, on business decisions before they are made. If you are looking to derive greater productivity from your mining operation, along with more holistic evaluation and reporting, we want to partner with you.



Project Experience

We pride ourselves on attention to detail and the ability to regularly provide a bulk material handling technology.

We offer a wide range of services all delivered in a professional fashion. The attention to detail and personal touch from our management team enables us to meet and even exceed our client's expectations time and time again.

We believe our system approach, commitment to service, and the ability to manufacture product to a customer's unique requirements is what differentiates us from the rest of the material handling world. Manufacturers who provide only standard or pre-engineered hardware often overlook the crucial system and application facets necessary for a fully integrated material handling system.

Here are just a few of our customers:



PT ROTOTEG TOTAL SOLUSI

HEAD OFFICE:

Jl. Kartini 18 No.31
GRESIK, JAWA TIMUR 61122

✉ info@rototeg.com

☎ +62 811-3288-883 (HUNTING)

BRANCH OFFICE:

Gedung Alamanda No.5 Pergudangan
Mangkupalas, Business Center

Jl. Trikora No. 12, Simpang Pasir, Kec. Palaran
SAMARINDA, KALIMANTAN TIMUR 75251

✉ ratih@rototeg.com

☎ +62 812-5040-0777 (HUNTING)